

Quad Occupancy Detector Assembly

Circuit board and components supplied in kits are RoHS compliant. Using RoHS-compliant (non-lead) solder will result in a finished board that is also RoHS compliant. If maintaining RoHS-compliance is not important to you, you may use solder containing lead.

To avoid excessive heating of components, it is recommended that one lead of each component at a time be soldered, followed by the same lead on each other component, before returning to the next lead of each component.

Component Order of Assembly

There is no mandatory order of assembly for components. However, the job may be a little easier by starting with the shortest components (ones that lie flattest on the board) and work towards the taller components.

Some components must be oriented correctly. These are described in the order of shortest to tallest:

- Resistors R1 .. R8
Orientation is not important.
R1, R3, R5, and R7 are 10 ohm and are blue in colour with colour bands: brown, black, black, gold, brown.
R2, R4, R6, and R8 are 2.7 kilo-ohm and are tan in colour with colour bands: red, violet, red, gold.
- Opto-couplers U1 .. U4
Pin 1 of the package must be oriented at the end with the notch image on the circuit board. Compare the image in Figure 1 where the notch appears to the left with the photo in Figure 2 where pin 1 is marked with a dot.
- Indicator LEDs LED1 .. LED4
LEDs have a flat edge, nearest their shortest lead, that must be oriented towards the device label on the board (e.g.: "LED1"). See photo in Figure 2 where the label and flat edge are at the top.
- Optional Capacitors C5 .. C8
These components are not included with the kit. If using one or all of them, this is the ideal time to install them on the board.
- Transistors Q1 .. Q4
Transistors must be oriented so that their package matches the image on the circuit board. Compare the image in Figure 1 with the photo in Figure 2. The flat edge of the transistors are at the top in both figures.

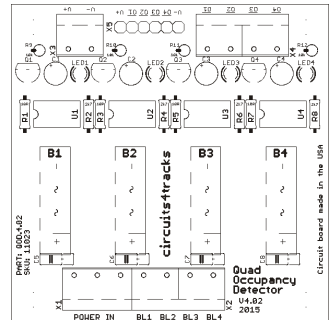

Figure 1



Figure 2

- SIP Header X5
Orientation is not important.
- Optional Resistors R9 .. R12
These components are not included with the kit. If using one or all of them, this is the ideal time to install them on the board. See the section titled "Optional Resistors" on page 4 for information on the installation of these components.
- Screw terminal blocks X1 .. X4
All terminal blocks should be oriented so that wire insertion openings face the edge of the board.

X1 uses a 2-terminal block that should be placed to use the first two positions, where the text "POWER IN" appears on the board.

X2 uses a 4-terminal block (or two 2-terminal blocks assembled together) that is placed to use the four positions, aligning each terminal with the labeling "BL1", "BL2", "BL3", and "BL4".

X3 uses a 2-terminal block.

X4 uses a 4-terminal block (or two 2-terminal blocks assembled together).

- Capacitors C1 .. C4
Capacitors must be oriented so that their longer lead goes through the hole marked with a "+".
- Bridge Rectifiers B1 .. B4
Diodes must be oriented such that the terminal labeled with "+" (the terminal at the end with a notch in the package) is positioned at the end closest to the track power terminal blocks, X1 and X2.

Warranty

Card and components are warranted against manufacturing defects for a period of 1 year from date of purchase. As the circumstances under which this kit is assembled and installed cannot be controlled, failure of the detector card due to assembly or installation problems cannot be warranted. This includes overheating during assembly, misuse, miswiring, operation under loads beyond its specifications, or short circuits. The warranty is voided if the detector card is connected to an output supply voltage more than 26 volts, used for a load greater than 190 milliamperes, or used for track power exceeding 4 amperes per block, or 16 amperes in total, including daisy-chained feeds.

If the detector card fails for non-warranted reasons, it can be replaced with no questions asked for the cost of \$24 plus shipping for an assembled card, or for \$12 plus shipping for a replacement kit (fees subject to change).

Email to circuits@daxack.ca for information on warranty or non-warranty replacement.

Installation

See the enclosed installation instruction sheet.

Optional Resistors

There are locations on the board for four resistors, one for each detector, labeled R9 to R12. These are shown in Figure 3. In most situations they are not used, however if a detector is feeding into a circuit that requires a low level voltage to be well below 0.7 volts, it will be necessary to install a 10k resistor for the corresponding detector and cut the

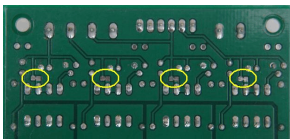

Figure 4

corresponding trace on the bottom of the circuit board. These resistors must be installed vertically with one lead bent around in the direction of the other. The cuttable trace locations are shown in Figure 4.

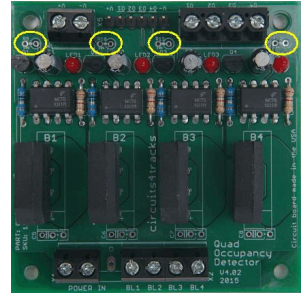

Figure 3

Performing this modification will result in a low level that is about 0.2 volts. Only make this modification if it is absolutely necessary as it will reduce sensitivity slightly.

Optional Capacitors

There are locations on the board for four capacitors, one for each detector, labeled C5 to C8. These are shown in Figure 5.

In most situations they are not used, however if wiring from the detector to the track is lengthy or if the block of track itself is lengthy, it is possible that the detector may produce a false occupancy reading for DCC or pulse-width-modulated DC. This is because higher frequencies will see the capacitance of the track and/or wiring to be a low impedance. This causes a small but detectable current, which results in a false occupancy indication.

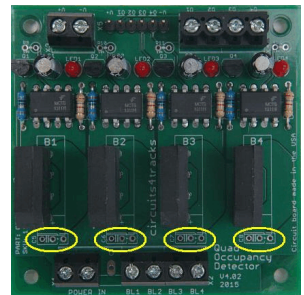
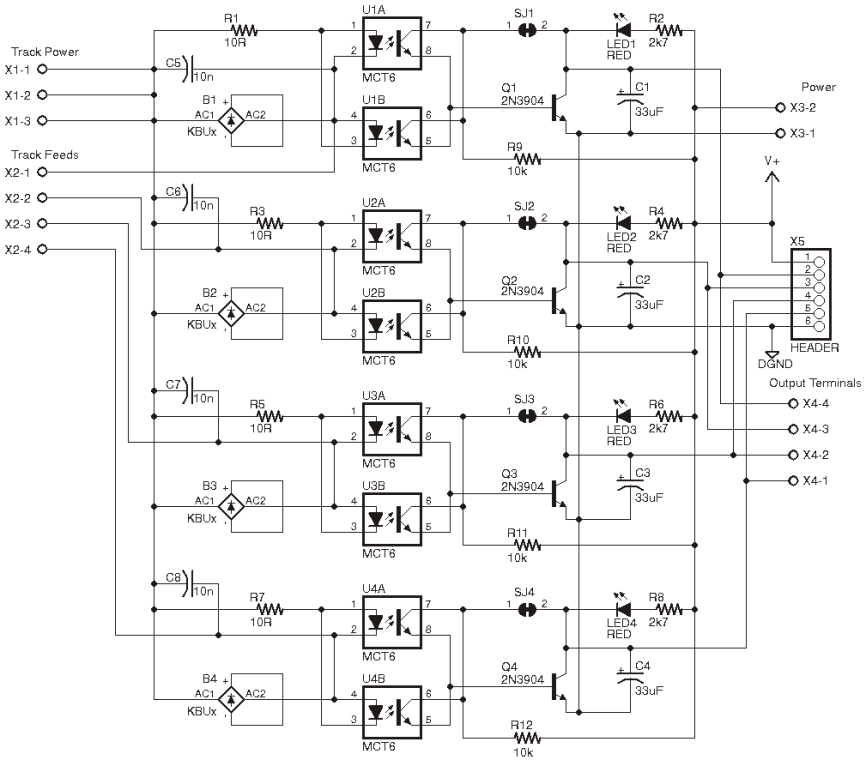

Figure 5

Installing a small capacitor, usually between 10 nF and 100 nF, allows this high frequency capacitive current to be shunted around the detection circuit. Only the intended train current draw will be detected. When installing a capacitor, one lead should use the left-most hole, while the other lead may use either of the other two, depending on its size.

Circuit Schematic



Component values:

R1, R3, R5, R7 10R, 1/4 watt

R2, R4, R6, R8 2k7, 1/4 watt

U1-U4 MCT6 Opto-coupler

B1-4 RS40xL (RS401L, RS402, etc)

High current (8 amp) option uses KBU80x with heat sink

Q1-4 2N3904

C1-4 33uF, 35 volt electrolytic

X1, X3 2-position screw terminal block

X2, X4 4-position screw terminal block

Two 2-position screw terminal blocks may be used in place of a 4-position

X5 6-pin header

Optional components:

C5-8 10n to 100n disc or ceramic capacitor, 50 volt or greater

R9-12 10k, 1/4 watt (must cut corresponding trace pad "SJx" when used)

This document is available in PDF format on our website.