

Quad Occupancy Detector Assembly

Circuit board and components supplied in kits are RoHS compliant. Using RoHS-compliant (non-lead) solder will result in a finished board that is also RoHS compliant. If maintaining RoHS-compliance is not important to you, you may use solder containing lead.

To avoid excessive heating of components, it is recommended that one lead of each component at a time be soldered, followed by the same lead on each other component, before returning to the next lead of each component.

Component Order of Assembly

There is no mandatory order of assembly for components. However, the job may be a little easier by starting with the shortest components (ones that lie flattest on the board) and work towards the taller components.

Some components must be oriented correctly. These are described in the order of shortest to tallest:

- Resistors R1 .. R8
Orientation is not important.
R1, R3, R5, and R7 are 10 ohm and are blue in colour with colour bands: brown, black, black, gold, brown.
R2, R4, R6, and R8 are 2.7 kilo-ohm and are tan in colour with colour bands: red, violet, red, gold.
- Opto-couplers U1 .. U4
Pin 1 of the package must be oriented at the end with the notch image on the circuit board. Compare the image in Figure 1 where the notch appears to the left with the photo in Figure 2 where pin 1 is marked with a dot.
- Indicator LEDs LED1 .. LED4
LEDs have a flat edge, nearest their shortest lead, that must be oriented towards the device label on the board (e.g.: "LED1"). See photo in Figure 2 where the label and flat edge are at the top.
- Transistors Q1 .. Q4
Transistors must be oriented so that their package matches the image on the circuit board. Compare the image in Figure 1 with the photo in Figure 2. The flat edge of the transistors are at the top in both figures.

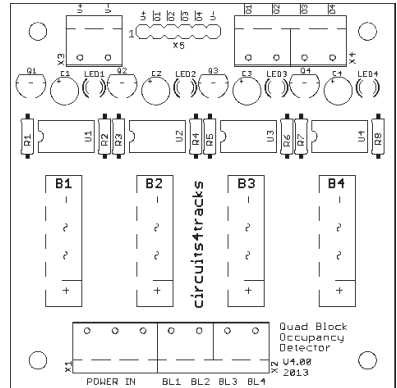

Figure 1

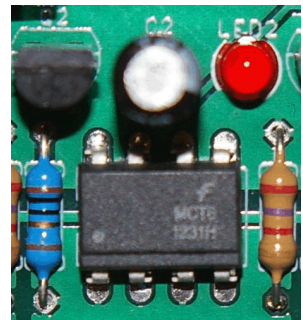

Figure 2

- SIP Header X5
Orientation is not important.
- Screw terminal blocks X1 .. X4
X1 uses a 2-terminal block that should be placed to use the first two positions, where the text "POWER IN" appears on the board. Block should be oriented so that wire insertion openings face the edge of the board.

X2 uses a 4-terminal block (or two 2-terminal blocks assembled together) that is placed to use the four positions, aligning each terminal with the labeling "BL1", "BL2", "BL3", and "BL4". Block should be oriented so that their insertion openings face the edge of the board.

X3 uses a 2-terminal block. Block should be oriented so that wire insertion openings face the edge of the board.

X4 uses a 4-terminal block (or two 2-terminal blocks assembled together). Block should be oriented so that wire insertion openings face the edge of the board.
- Capacitors C1 .. C4
Capacitors must be oriented so that their longer lead goes through the hole marked with a "+".
- Bridge Rectifiers B1 .. B4
Diodes must be oriented such that the terminal labeled with "+" (the terminal at the end with a notch in the package) is positioned at the end closest to the track power terminal blocks, X1 and X2.

Installing Detector

See the enclosed installation instruction sheet.

Warranty

Card and components are warranted against manufacturing defects for a period of 1 year from date of purchase. As the circumstances under which this kit is assembled and installed cannot be controlled, failure of the detector card due to assembly or installation problems cannot be warranted. This includes over-heating during assembly, misuse, miswiring, operation under loads beyond its specifications, or short circuits. The warranty is voided if the detector card is connected to an output supply voltage more than 26 volts, used for a load greater than 190 milliamperes, or used for track power exceeding 4 amperes per block, or 16 amperes in total, including daisy-chained feeds.

If the detector card fails for non-warranted reasons, it can be replaced with no questions asked for the cost of \$24 plus shipping for an assembled card, or for \$12 plus shipping for a replacement kit (fees subject to change).

Send an email to circuits@daxack.ca for information on warranty or non-warranty replacement.

Circuit Schematic

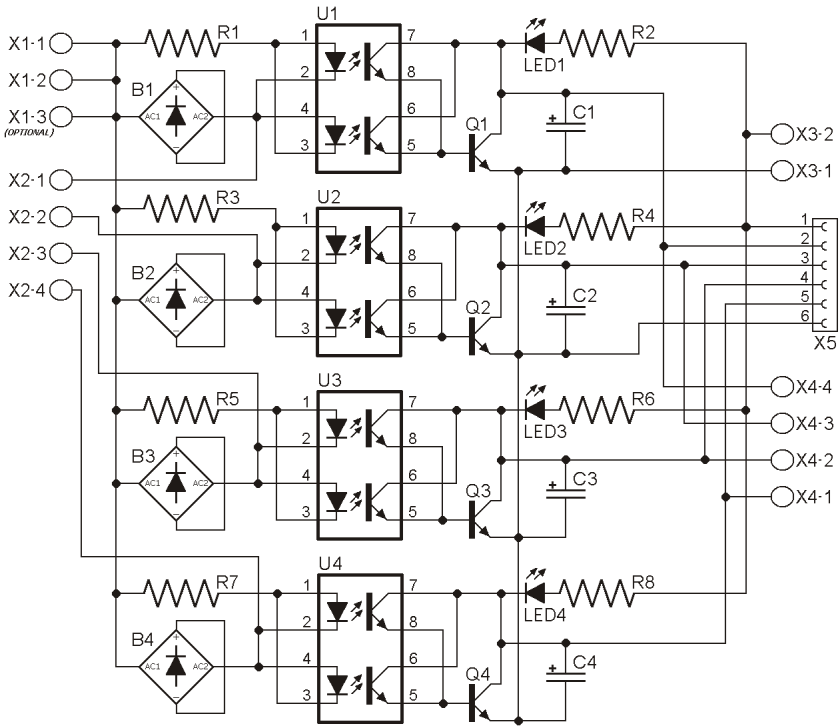

Part values:

- R1, R3, R5, R7 10R, ¼ watt
- R2, R4, R6, R8 2k7, ¼ watt
- U1-U4 MCT6 Opto-coupler
- B1-4 RS40xL (RS401L, RS402, etc)
High current (8 amp) option uses KBU80x with heat sink
- Q1-4 2N3904
- C1-4 33µF, 35 volt electrolytic
- X1, X3 2-position screw terminal block
- X2, X4 4-position screw terminal block
Two 2-position screw terminal blocks may be used in place of a 4-position
- X5 6-pin header

This document is available in PDF format on our website.